



## INSTRUCTION MANUAL

---

**PADDLE TYPE LEVEL**

**MODEL: HL-400**

---

Meanings of indications for safety used in this Instruction Manual are as follows.



**WARNING:** Indicates that improper handling assumes the risk of a fatal or serious injury.



**CAUTION:** Indicates that improper handling assumes the risk of injury or damage to property only.

---

## TOWA SEIDEN INDUSTRIAL CO., LTD.

**HEAD OFFICE** Phone: 81-6-6340-5522, Fax: 81-6-6340-5519

**TOKYO OFFICE** Phone: 81-3-5484-2171, Fax: 81-3-5484-2175

**NAGOYA OFFICE** Phone: 81-52-937-5817, Fax: 81-52-937-5836

**OSAKA PLANT** Phone: 81-6-6340-2831, Fax: 81-6-6349-6551

URL <http://www.towa-seiden.co.jp>

No.EH41000-3

2009. 01. 09. 改訂  
2011. 01. 18. 改訂  
2011. 12. 20. 改訂

## Table of Contents

[1] Operation Principle .....	2
[2] Standard Specifications.....	2
2-1. Outline drawings.....	2
2-2. Specifications.....	2
[3] Type.....	3
[4] Precautions on Handling.....	4
4-1. Determining installation location.....	4
4-2. Impact of granules.....	4
[5] Mounting.....	4
5-1 Mounting direction.....	4
5-2. How to mount the product.....	4
5-2-1. Standard specifications (G3/4" Tightening with a locknut).....	4
5-2-2. N Type (Vane-Main shaft separate type).....	5
5-2-3. F Type (Mounting with a flange).....	5
[6] Wiring.....	5
6-1. Precautions on wiring.....	5
6-2. Wiring procedure.....	6
[7] Detection Torque.....	7
[8] Replacing Internal Mechanisms.....	7
[9] Operation Check Procedure.....	8
[10] Paddle-Type Level Switch Problem Prevention.....	8

## [1] Operation Principle

The paddle-type level switch rotates a vane mounted on the main shaft with a motor. When no load is applied to the vane by the measurement target, the motor constantly rotates. When the vane stops rotating due to the measurement target, the switch stops the motor and delivers a contact output. At this time, the motor power source is set to shut off to protect the motor.

When the force stopping the motor rotation is removed, the power supply to the motor turns on to rotate the motor, and the contact output switches. This operation detects the measurement target.

## [2] Standard Specifications

### 2-1. Outline drawings

(Type: HL – 400)

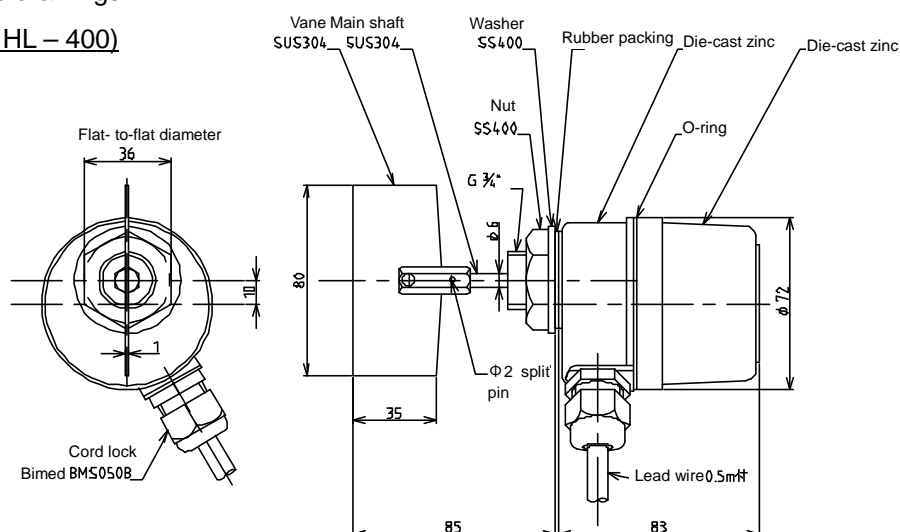

### 2-2. Specifications

Power supply voltage	AC 100/110 V 50/60 Hz or AC 200/220 V 50/60 Hz
Mounting Method	G3/4" (Tightening the base mounting plate with a locknut)
Power consumption	1.5 W
Contact output	1C Contact AC 250 V 5 A (Resistance load)
Detection torque (*1)	About 4.9 N·cm
Slip torque (*2)	About 11.76 - 14.70 N·cm
Number of rotations	1 rpm
Materials	Product body chassis and cover Die-cast zinc Main shaft and vane SUS304 Sealing Nitrile rubber
Ambient temperature during use	Inside the tank 60°C max Outside the tank 55°C max
Pressure during use	Inside the tank 0 – 0.49 kPa
Painting color	Munsell 7.5GB4/15

(\*1) Detection torque is the torque value necessary to stop motor rotation.

(\*2) Slip torque is a torque value at which the pullout mechanism is activated. The pullout mechanism protects the motor when the vane experiences an overload or impact.

Individual specifications are provided separately. Please contact our sales representatives.

[3] Type

HL-400



None	Standard specifications
N	Vane-Main shaft Separate type
F	Flange mounting (Square 80 x 80 mm Mounting hole diagonal dimension 92 mm 4 - $\phi$ 7.2 )
H	Heat resistance specification 100°C max.
HH	Heat resistance specification 150°C max.
S	Portion contacting granules SUS - 304 specification
G	Specifications for products with a protective tube (L - 150 to 300, in units of 50 mm)
GS	Specifications for products with a protective tube (L - 150 to 300, in units of 50 mm) Portion contacting granules SUS - 304 specification
HS	Heat resistance specification 100°C max. Portion contacting granules SUS - 304 specification
HHS	Heat resistance specification 150°C max. Portion contacting granules SUS - 304 specification
HG	Heat resistance specification 100°C max. Specifications for products with a protective tube (L - 150 to 300, in units of 50 mm)
HHG	Heat resistance specification 150°C max. Specifications for products with a protective tube (L - 150 to 300, in units of 50 mm)
HGS	Heat resistance specification 100°C max. Specifications for products with a protective tube (L - 150 to 300, in units of 50 mm) Portion contacting granules SUS - 304 specification
HHGS	Heat resistance specification 150°C max. Specifications for products with a protective tube (L - 150 to 300, in units of 50 mm) Portion contacting granules SUS - 304 specification

None	Standard contact output 1C Contact AC 250 V 5A (Resistance load)
Z	For small load application 1C Contact AC 250 V 0.1 A (Resistance load)
ZE	For small load application 1C Contact AC 250 V 0.1 A (Resistance load) Equipped with a ground wire.



[4] Precautions on Handling

4-1. Determining installation location

Mount the product in a location where granule levels actually vary.

<Mounting the product at the upper limit level> <Mounting the product at the lower limit level>

Wrong example

Correct example

Wrong example

Correct example

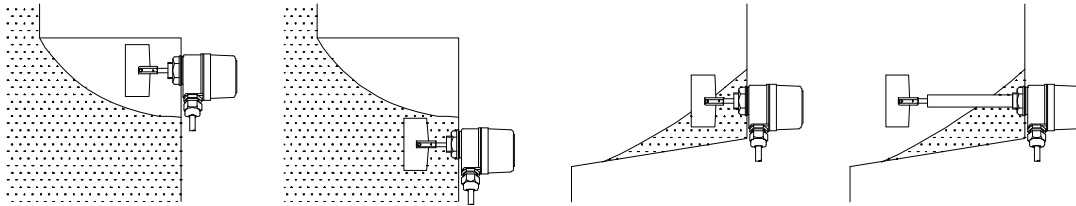

4-2. Impact of granule

If the product is mounted directly below the falling granules, the product may sometimes be damaged by the impact caused by the collapse of the bridge phenomenon in the hopper. Change the mounting position or provide a protective plate.

[5] Mounting

5-1. Recommended position of the mounting direction.

It is recommended that, for horizontal mounting, the cord lock face the direction as shown in the figure below. This position provides stable detection operation because of the product structure. Pay attention because setting the cord lock in the opposite direction may cause malfunction of the rotation recovery failure when the spring position changes.

\* Avoid using the product at the first position from "Weak" as much as possible.

<Product appearance viewing the vane to the left>

<Product appearance viewing the cover at the front>

A position where the cord lock is slanted by 25° - 30° from the bottom toward the front side

A position where the cord lock is slanted by 25° - 30° from the bottom toward the left side



5-2. How to Mount the Product

5-2-1. Standard Specifications (G3/4" Tightening with a locknut)

Mount the product body after removing the vane by taking the split pin out of the vane portion. After mounting the body, load the vane and fix it with the split pin. In fixing the vane, pay close attention and handle the split pin properly so that it does not come off. After completing the mounting, rotate the vane slowly half turn by hand until it reaches the position where it clicks.

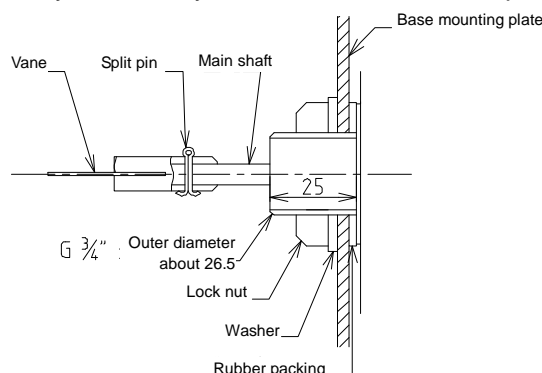

### 5-2-2. N Type (Vane-Main shaft separate type)

Mount the product body after removing the main shaft portion from the product body by loosening the hexagonal cap nut. Pay close attention so that no foreign matter enters inside the product body chassis because the chassis portion where the main shaft has been separated has a hollow structure. After mounting the body, load the main shaft and tighten the hexagonal cap nut. Make sure that the nut is tightened fully. After completing the mounting, rotate the vane slowly one-half turn by hand until it reaches the position where it clicks.

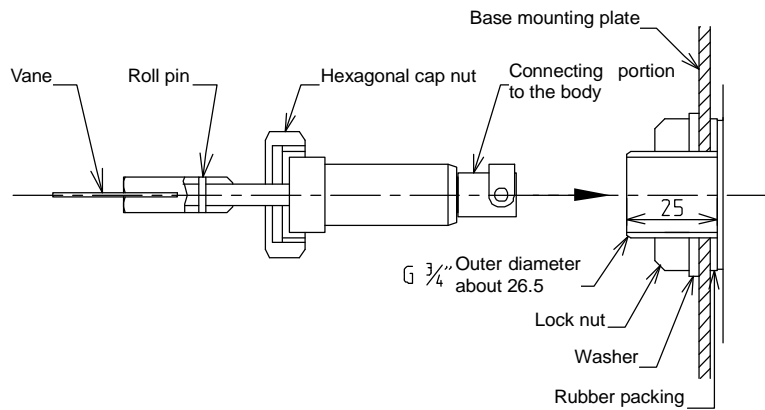

### 5-2-3. F Type (Mounting with a flange)

Implement mounting after preparing the proper flange and packing referring to the figure below. When mounting, pay close attention to avoid damaging the vane and lead wires. After completing the mounting, rotate the vane slowly one-half turn by hand until it reaches the position where it clicks.

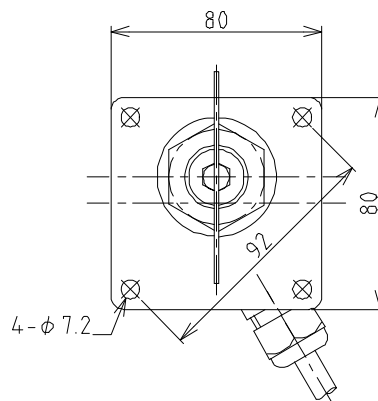

## [6 ] Wiring

### 6-1. Precautions on wiring



Warning

Warning During the wiring, make sure that the supply power sources and power sources applied to the output are shut off. Failure to do so may result in danger of electric shock, electric leaks, and short circuits or combustion.



Warning

The power source voltage for this product is 100 V and 200 V exclusively. Check the identification label at the bottom of the product body cover to be sure to avoid any error.



Caution

Do not connect a load that exceeds the rating of the contacts. Doing so may cause damage or deterioration of the contacts. If the load capacity exceeds the ratings for the contacts, install a relay that meets the load capacity between the load and the output terminal of the product. Do not connect the power supply directly to the relay output terminal without connecting a load. Doing so may cause a short circuit or may damage the product. (Check the ratings of the contacts found on the identification label on the bottom of the product body cover.)

## 6.2 Wiring procedure

Check the product and select the wiring diagram that matches the product referring to the table below before starting the wiring. The wiring diagram is also found on the identification label on the bottom of the product body cover. \* The wiring diagram corresponds to the status where the vane is rotating

H: Not conductive to C during vane rotation L: Conductive to C during vane rotation C: Common signal line

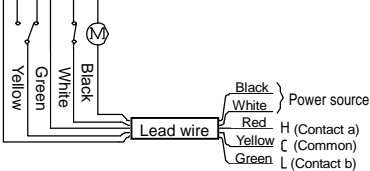
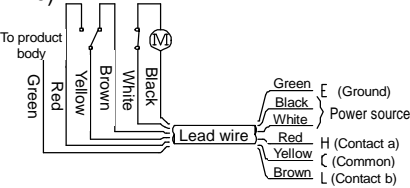
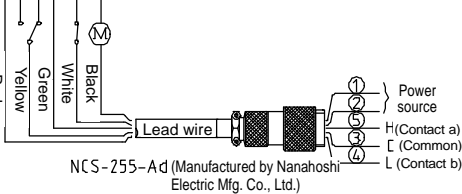
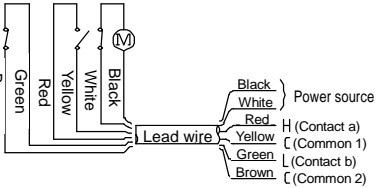
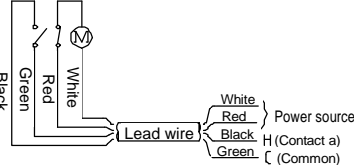
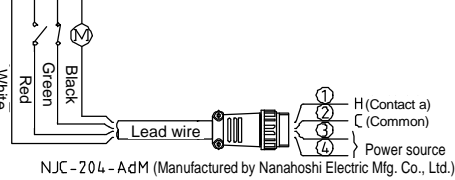
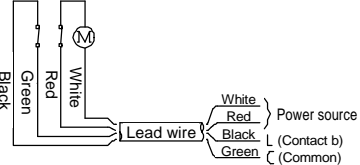
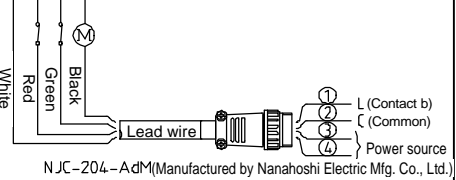
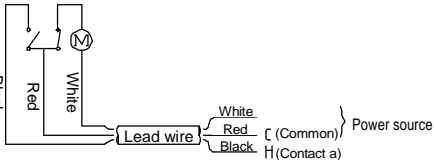
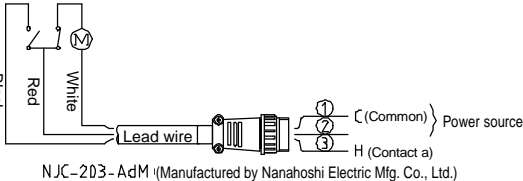
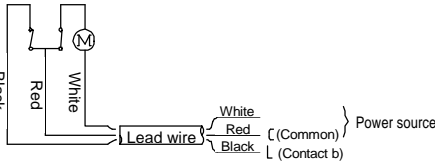
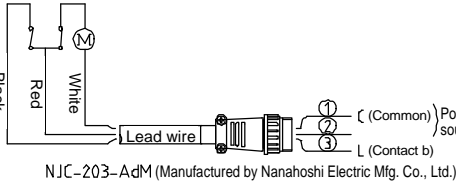
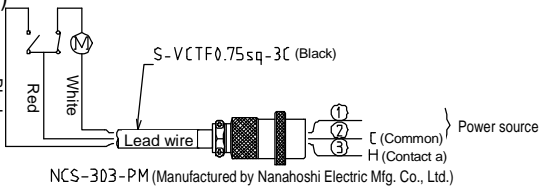
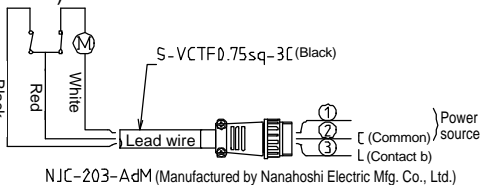
Standard specifications		Standard specifications
<p><b>5-core lead wire</b></p>  <p><b>Type ZE (Equipped with a small load ground wire)</b></p> 	<p><b>Equipped with 5P connector</b></p>  <p>NCS-255-Ad (Manufactured by Nanahoshi Electric Mfg. Co., Ltd.)</p> <p><b>Type -6P (2-contact output)</b></p> 	
For Particular Equipment Application		For Particular Equipment Application
<p><b>Type -4PA (4-core lead wire)</b></p>  <p><b>Type -4PA (Equipped with a 4P connector)</b></p>  <p>NJC-204-AdM (Manufactured by Nanahoshi Electric Mfg. Co., Ltd.)</p>	<p><b>Type -4PB (4-core lead wire)</b></p>  <p><b>Type -4PB (Equipped with a 4P connector)</b></p>  <p>NJC-204-AdM (Manufactured by Nanahoshi Electric Mfg. Co., Ltd.)</p>	
<p><b>Type -3PA (3-core lead wire)</b></p>  <p><b>Type -3PA (Equipped with a 3P connector)</b></p>  <p>NJC-203-AdM (Manufactured by Nanahoshi Electric Mfg. Co., Ltd.)</p>	<p><b>Type -3PB (3-core lead wire)</b></p>  <p><b>Type -3PB (Equipped with a 3P connector)</b></p>  <p>NJC-203-AdM (Manufactured by Nanahoshi Electric Mfg. Co., Ltd.)</p>	
<p><b>Type -3PA (Equipped with a 3P connector, black lead wire)</b></p>  <p>NCS-303-PM (Manufactured by Nanahoshi Electric Mfg. Co., Ltd.)</p>	<p><b>Type -3PB (Equipped with a 3P connector, black lead wire)</b></p>  <p>NJC-203-AdM (Manufactured by Nanahoshi Electric Mfg. Co., Ltd.)</p>	

## [7] Detection Torque

If you need to increase the detection sensitivity because of apparent relative density or the heap condition of the material, then increase the vane dimension. When changes in the vane shape are difficult due to the shape of the hopper, then increase the detection sensitivity by a small amount by shifting the spring position located at the back of the internal mechanism toward the “Weak” direction. In shifting the position, pay particular attention not to deform the spring. Failure to do so may cause malfunction of the product. In the case of vertical mounting, do not shift the spring position toward the “Weak” direction. Doing so may cause a malfunction of the rotation recovery failure.

\* Avoid using the product at the first position from “Weak” as much as possible.

<Spring position by default>

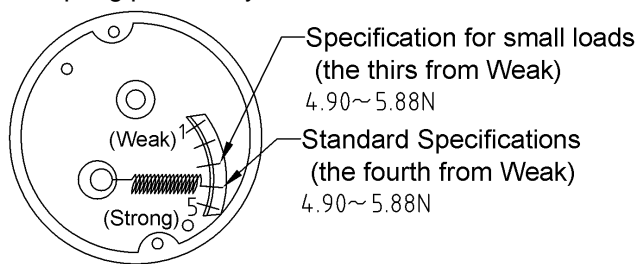

\*Do not change the spring position in the vertical mounting.

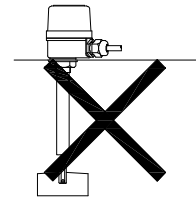

## [8] Replacing Internal Mechanisms



Warning

Warning During internal mechanism replacement, be sure that the supply power sources and power sources applied to the output are shut off. Failure to do so may result in danger of electric shock, electric leaks, and short circuits or combustion.

- 1) Remove the cover. The cover has a threaded mounting for the chassis.
- 2) Loosen the lead-holding portion of the cord lock. (Have the wiring removed in advance since the entire lead wire is replaced.)
- 3) Remove the internal mechanism. Use the proper Phillips screwdriver to remove the internal mechanism, which is attached to the chassis with two M4 screws.
- 4) Pull the internal mechanism toward you to remove it along with the lead wire.
- 5) Prepare the replacement internal mechanism. Run the lead wire from inside the chassis through the cord lock, adjust the coated portion of the lead to the rear end of the cord lock, and then secure the lead wire. During this work, pay attention not to damage the lead wire. Also, pay attention not to twist the conducting wires.
- 6) Fit the motor output portion of the internal mechanism into the motor junction portion and secure the internal mechanism with screws. In the attachment process, pay close attention to avoid pinching, twisting, or forcibly attaching the conductor wires.
- 7) Mount the cover.

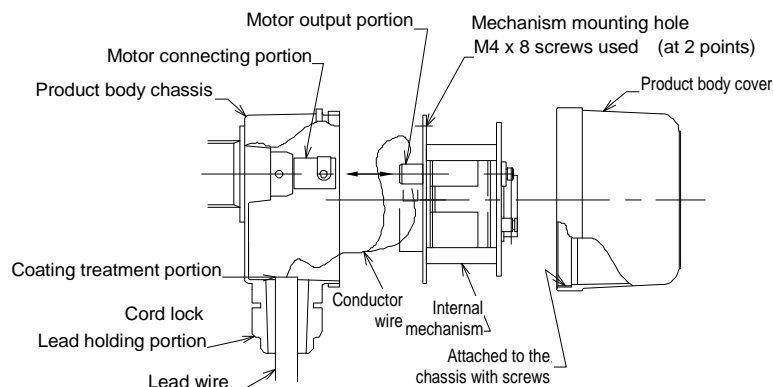



[9] Operation Check Procedure

- 1) Check whether the wiring is correctly connected.
- 2) Turn the power on.
- 3) Check that the vane rotates smoothly.
- 4) Check that the signal switches when the vane is held by hand or completely buried in the measurement target. (2–3 times during one rotation)
- 5) Rotate the vane by hand and check that the vane runs idle and clicks at the position after rotating 180°. (Check slip mechanism operation)

[10] Paddle-Type Level Switch Problem Prevention

- 1) Do not expose the switch body to impacts.
- 2) Check that the vane, main shaft, and protective tube have no bends.
- 3) Pay attention to tighten the cover to prevent intrusion of rainwater or dust.
- 4) Check that no measuring object adheres to the vane and main shaft.
- 5) Do not deform the spring during the detection torque adjustment. Doing so may make detection impossible.
- 6) In detection torque adjustment, avoid the first position from “Weak” as much as possible.
- 7) Be sure to connect the correct power source voltage.
- 8) Do not mistake the power wire and output wire when wiring.
- 9) Do not apply current in excess of the ratings to the output contact or do not short circuit the output contact.
- 10) When wiring, use the proper crimp terminals to prevent the wires from coming off.
- 11) When performing terminal treatment of the lead wire, pay close attention to avoid damaging the conductors and coating.

Examples of abnormality in detection operation (outline)

Abnormal state	Material in the tank	Level switch defective state	
		Main shaft rotation	Signal switching
Signal does not switch to the direction identifying the existence of material despite its existence.	The material has formed a bridge, creating a hollow near the vane, resulting in idling of the vane.	<ol style="list-style-type: none"> <li>1. Power source · voltage</li> <li>2. Defective motor</li> </ol>	<ol style="list-style-type: none"> <li>1. Contact failure of microswitch contacts</li> <li>2. Burnout of microswitch contacts due to excess current</li> </ol>
Signal does not switch to the direction identifying the non-existence of material despite its non-existence.	Material adheres to the tank wall and the vane, forming a heap.	<ol style="list-style-type: none"> <li>1. Recovery action failure due to clogging at the sealing portion.</li> <li>2. Defective recovery spring</li> <li>3. Bent main shaft</li> <li>4. Deformed product body</li> </ol>	<ol style="list-style-type: none"> <li>1. Contact failure of microswitch contacts</li> <li>2. Burnout of microswitch contacts due to excess current</li> </ol>